

SPM/SPB to E-Z-GO TXT

Year: 1994-Present

1206 REPLACEMENT SERIES MOTOR

SPB EZ MODEL SHOWN
 EZ MODELS PROVIDE BOTH THE EZGO CONNECTOR FOR CARTS WITH STOCK WIRING AND 4 SPARE TERMINALS FOR CARTS MODIFIED PREVIOUSLY TO USE ALLTRAX AKE CONTROLLERS FOR YOUR CONVENIENCE.

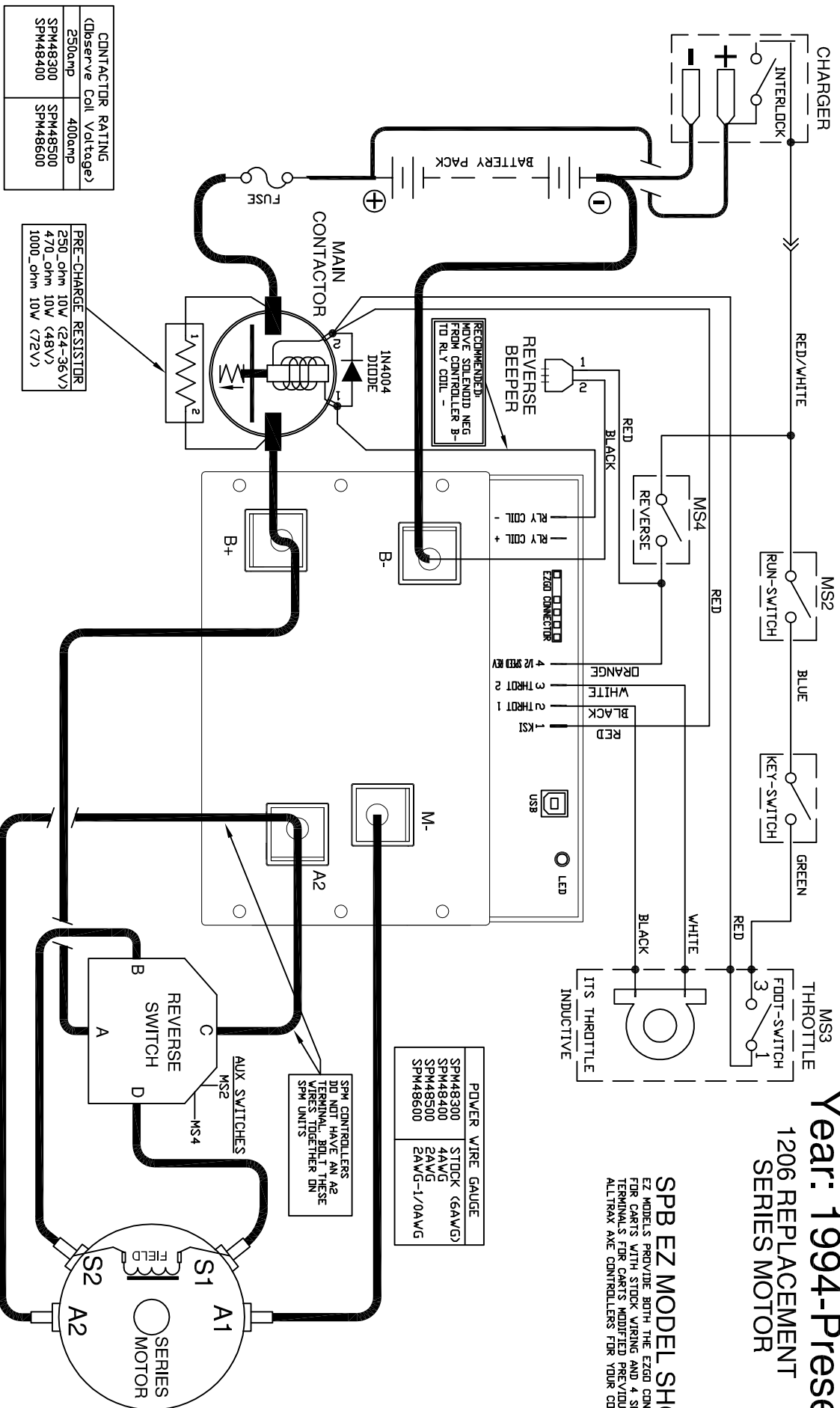

TAB	FUNCTION
1	KSI VOLTAGE
2	THROTTLE
3	THROTTLE
4	1/2 SPEED REVERSE
B+	BATTERY POSITIVE
B-	BATTERY NEGATIVE
M-	MOTOR MINUS

- NOTES:**
- * FUSES REQUIRED FOR ALL INSTALLATIONS
 - * DIODE REQUIRED ACROSS COILS / RELAYS
 - * PRE-CHARGE RESISTOR REQUIRED
 - > ASSUMES FOOTSWITCH IS OPEN WHEN THROTTLE OFF WITHOUT NOTICE
 - > ALLTRAX RESERVES THE RIGHT TO CHANGE DOCUMENTATION WITHOUT NOTICE
 - > ALLTRAX MAKES NO WARRANTY AS TO THE ACCURACY, SUFFICIENCY, OR SUITABILITY OF ANY TECHNICAL OR OTHER INFORMATION PROVIDED
 - > SEE OPERATORS MANUAL FOR MORE INFORMATION

REVISIONS		
REV.	ECO.	DATE

DWG SCALE: 1:1
 DWG: RICHARD CSUK 11/16/10
 ENGR: DAVID CROCKETT 11/16/10

ALLTRAX 1111 Cheney Creek Rd.
 Grants, OR 97527
 PHONE: (541) 476-3565

TITLE: SPM/SPB - EZGO 1206 Replacement
 Wiring Diagram

SIZE: A
 DOCUMENT NO.: DDC110-001
 REV.: A

FILE: DDC110-001-A-DWG-SPB-EZGO-TXT-AKE-DWG

SHEET 1 OF 1